

Mathematics 110 – Calculus of one variable
Trent University 2001-2002

SKELETAL SOLUTIONS TO THE QUIZZES

Quiz #1. Friday, 21 September, 2001. [15 minutes]

- Sketch the graph of a function $f(x)$ with domain $(-1, 2)$ such that $\lim_{x \rightarrow 2} f(x) = 1$ but $\lim_{x \rightarrow -1} f(x)$ does not exist. [4]
- Use the $\epsilon - \delta$ definition of limits to verify that $\lim_{x \rightarrow \pi} 3 = 3$. [6]

Solutions.

- The graph here does the job:

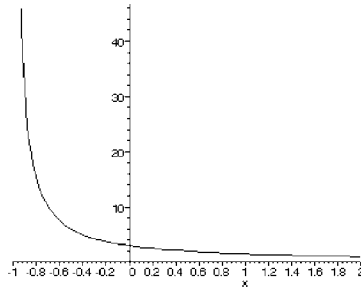

This is the graph of $f(x) = \frac{3}{x+1}$ for $-1 < x < 2$, which does the job since $\lim_{x \rightarrow -1^-} \frac{3}{x+1} = \infty$ and $\lim_{x \rightarrow 2^+} \frac{3}{x+1} = \frac{3}{3} = 1$. ■

- We need to check that for any $\epsilon > 0$ there is some $\delta > 0$ such that if $|x - \pi| < \delta$, then $|3 - 3| < \epsilon$. Now, given any $\epsilon > 0$, $|3 - 3| = 0 < \epsilon$, so *any* $\delta > 0$ does the job ■

Quiz #2. Friday, 28 September, 2001. [15 minutes]

Evaluate the following limits, if they exist.

$$1. \quad \lim_{x \rightarrow -1} \frac{x+1}{x^2-1} \quad [5] \qquad 2. \quad \lim_{x \rightarrow 1} \frac{x+1}{x^2-1} \quad [5]$$

Solutions.

- $\lim_{x \rightarrow -1} \frac{x+1}{x^2-1} = \lim_{x \rightarrow -1} \frac{x+1}{(x-1)(x+1)} = \lim_{x \rightarrow -1} \frac{1}{x-1} = \frac{1}{-1-1} = -\frac{1}{2}$ ■
- $\lim_{x \rightarrow 1} \frac{x+1}{x^2-1} = \lim_{x \rightarrow 1} \frac{x+1}{(x-1)(x+1)} = \lim_{x \rightarrow 1} \frac{1}{x-1} = \pm\infty$ (The \pm depends on whether x approaches 1 from the right or the left.) Hence $\lim_{x \rightarrow 1} \frac{x+1}{x^2-1}$ does not exist. ■

Quiz #3. Friday, 5 October, 2001. [20 minutes]

$$1. \text{ Is } g(x) = \begin{cases} \frac{x^2 - 6x + 9}{x - 3} & x \neq 3 \\ 0 & x = 3 \end{cases} \text{ continuous at } x = 3? \quad [5]$$

- For which values of c does $\lim_{x \rightarrow \infty} \frac{13}{cx^2 + 41}$ exist? [5]

Solutions.

1. This boils down to checking whether $\lim_{x \rightarrow 3} \frac{x^2 - 6x + 9}{x - 3} = 0$ or not.

$$\lim_{x \rightarrow 3} \frac{x^2 - 6x + 9}{x - 3} = \lim_{x \rightarrow 3} \frac{(x - 3)^2}{x - 3} = \lim_{x \rightarrow 3} x - 3 = 3 - 3 = 0$$

It follows that $f(x)$ is continuous at $x = 3$. ■

2. First, if $c = 0$, $\lim_{x \rightarrow \infty} \frac{13}{cx^2 + 41} = \lim_{x \rightarrow \infty} \frac{13}{41} = \frac{13}{41}$. Second, if $c \neq 0$, then $\lim_{x \rightarrow \infty} cx^2 + 41 = \pm\infty$, depending on whether $c > 0$ or $c < 0$, but then $\lim_{x \rightarrow \infty} \frac{13}{cx^2 + 41} = 0$.

Either way, $\lim_{x \rightarrow \infty} \frac{13}{cx^2 + 41}$ exists no matter what the value of the constant c happens to be. ■

Quiz #4. Friday, 12 October, 2001. [10 minutes]

1. Use the definition of the derivative to find $f'(x)$ if $f(x) = \frac{5}{7x}$. [10]

Solutions.

1.

$$\begin{aligned} f'(x) &= \lim_{h \rightarrow 0} \frac{f(x+h) - f(x)}{h} = \lim_{h \rightarrow 0} \frac{\frac{5}{7(x+h)} - \frac{5}{7x}}{h} = \lim_{h \rightarrow 0} \frac{\frac{5 \cdot 7x - 5 \cdot 7(x+h)}{7(x+h) \cdot 7x}}{h} \\ &= \lim_{h \rightarrow 0} \frac{35x - 35x - 35h}{49xh(x+h)} = \lim_{h \rightarrow 0} \frac{-35h}{49xh(x+h)} = \lim_{h \rightarrow 0} \frac{-5}{7x(x+h)} = -\frac{5}{7x^2} \quad \blacksquare \end{aligned}$$

Quiz #5. Friday, 19 October, 2001. [17 minutes]

Compute $\frac{dy}{dx}$ for each of the following:

1. $y = \frac{2x+1}{x^2}$ [3] 2. $y = \ln(\cos(x))$ [3] 3. $y = (x+1)^5 e^{-5x}$ [4]

Solutions.

1. $\frac{dy}{dx} = \frac{2 \cdot x^2 - (2x+1) \cdot 2x}{x^4} = \frac{2x^2 - 4x^2 - 2x}{x^4} = \frac{-2x(x+1)}{x^4} = \frac{-2(x+1)}{x^3}$ ■

2. $\frac{dy}{dx} = \frac{1}{\cos(x)} \cdot \frac{d}{dx} \cos(x) = \frac{1}{\cos(x)} \cdot (-\sin(x)) = -\frac{\sin(x)}{\cos(x)} = -\tan(x)$ ■

3.

$$\begin{aligned} \frac{dy}{dx} &= 5(x+1)^4 \cdot e^{-5x} + (x+1)^5 \cdot (-5)e^{-5x} \\ &= 5(x+1)^4 e^{-5x} - 5(x+1)^5 e^{-5x} \\ &= 5(x+1)^4 e^{-5x} (1 - (x+1)) \\ &= -5x(x+1)^4 e^{-5x} \quad \blacksquare \end{aligned}$$

Quiz #6. Friday, 2 November, 2001. [20 minutes]

Find $\frac{dy}{dx}$...

1. ... at the point that $y = 3$ and $x = 1$ if $y^2 + xy + x = 13$. [4]
2. ... in terms of x if $e^{xy} = x$. [3]
3. ... in terms of x if $y = x^{3x}$. [3]

Solutions.

1. We'll use implicit differentiation. Differentiating both sides of $y^2 + xy + x = 13$ with respect to x and solving for $\frac{dy}{dx}$ gives:

$$\begin{aligned}2y \frac{dy}{dx} + 1y + x \frac{dy}{dx} + 1 &= 0 \\ \iff (2y + x) \frac{dy}{dx} + (y + 1) &= 0 \\ \iff \frac{dy}{dx} &= \frac{-(y + 1)}{2y + x}\end{aligned}$$

When $y = 3$ and $x = 1$, we get:

$$\left. \frac{dy}{dx} \right|_{x=1 \text{ \& } y=3} = -\frac{3 + 1}{2 \cdot 3 + 1} = -\frac{4}{7} \quad \blacksquare$$

2. In the case of $e^{xy} = x$, it is easiest to solve for y first ...

$$e^{xy} = x \iff xy = \ln(x) \iff y = \frac{\ln(x)}{x}$$

... and then differentiate using the quotient rule:

$$\frac{dy}{dx} = \frac{\frac{1}{x} \cdot x - \ln(x) \cdot 1}{x^2} = \frac{1 - \ln(x)}{x^2} \quad \blacksquare$$

3. $y = x^{3x}$ is a job for logarithmic differentiation. First,

$$y = x^{3x} \iff \ln(y) = \ln(x^{3x}) = 3x \ln(x),$$

and differentiating both sides gives

$$\begin{aligned}\frac{d}{dx} \ln(y) &= \frac{d}{dx} 3x \ln(x) \iff \left(\frac{d}{dy} \ln(y) \right) \left(\frac{dy}{dx} \right) = 3 \cdot \ln x + 3x \cdot \frac{1}{x} \\ &\iff \frac{1}{y} \cdot \frac{dy}{dx} = 3 \ln(x) + 3.\end{aligned}$$

Solving for $\frac{dy}{dx}$ and substituting back for y now gives:

$$\frac{dy}{dx} = 3y(\ln(x) + 1) = 3x^{3x}(\ln(x) + 1) \quad \blacksquare$$

Quiz #7. Friday, 9 November, 2001. [13 minutes]

1. Find all the maxima and minima of $f(x) = x^2e^{-x}$ on $(-\infty, \infty)$ and determine which are absolute. [10]

Solutions.

1. First,

$$f'(x) = 2x \cdot e^{-x} + x^2 \cdot (-e^{-x}) = 2xe^{-x} - x^2e^{-x} = x(2-x)e^{-x},$$

which equals 0 exactly when $x = 0$ or $x = 2$. (Note that $e^{-x} > 0$ for all x .) When $x < 0$, $x < 0$ and $2 - x > 0$, so $f'(x) < 0$; when $0 < x < 2$, $2 - x > 0$ and $x > 0$, so $f'(x) > 0$; and when $x > 2$, $2 - x < 0$ and $x > 0$, so $f'(x) < 0$. Thus

x	$x < 0$	$x = 0$	$0 < x < 2$	$x = 2$	$2 < x$
$f'(x)$	< 0	0	> 0	0	< 0
$f(x)$	decreasing	local min	increasing	local max	decreasing

so $f(0) = 0$ is a local minimum and $f(2) = 4/e^2$ is a local maximum.

It remains to check whether either local extreme point is an absolute extreme point of the function. This can be done by taking the limit of $f(x)$ as $x \rightarrow \infty$ and as $x \rightarrow -\infty$, but that is overkill for this problem. It is enough to note that $f(x) = x^2e^{-x} \geq 0$ for all x , so $f(0) = 0$ is an absolute minimum, but that $f(-4) = (-4)^2e^{-(-4)} = 16e^4 > 4/e^2 = f(2)$, so $f(2) = 4/e^2$ is not an absolute maximum. \blacksquare

Quiz #8. Friday, 23 November, 2001. [15 minutes]

1. A spherical balloon is being inflated at a rate of $1 \text{ m}^3/\text{s}$. How is the diameter of the balloon changing at the instant that the radius of the balloon is 2 m ? [10]
[The volume of a sphere of radius r is $V = \frac{4}{3}\pi r^3$.]

Solution.

1. Since $V = \frac{4}{3}\pi r^3$,

$$1 = \frac{dV}{dt} = \frac{dV}{dr} \cdot \frac{dr}{dt} = \frac{d}{dt} \left(\frac{4}{3}\pi r^3 \right) \cdot \frac{dr}{dt} = \left(\frac{4}{3}\pi \cdot 3r^2 \right) \cdot \frac{dr}{dt} = 4\pi r^2 \cdot \frac{dr}{dt}.$$

It follows that $\frac{dr}{dt} = \frac{1}{4\pi r^2}$. At the instant in question, $r = 2$, so we have $\frac{dr}{dt} = \frac{1}{4\pi 2^2} = \frac{1}{16\pi}$.

Since the diameter, call it s , is twice the radius of the sphere, *i.e.* $s = 2r$, it follows that at the instant that $r = 2 \text{ m}$, the diameter is changing at a rate of $\frac{ds}{dt} = \frac{d}{dt}(2r) = 2\frac{dr}{dt} = 2 \cdot \frac{1}{16\pi} = \frac{1}{8\pi} \text{ m/s}$. \blacksquare

Quiz #9. Friday, 30 November, 2001. [20 minutes]

1. Use the Right-hand Rule to compute $\int_0^3 (2x^2 + 1) dx$. [6]

[You may need to know that $\sum_{i=1}^n i^2 = \frac{n(n+1)(2n+1)}{6}$.]

2. Set up and evaluate the Riemann sum for $\int_0^2 (3x+1)dx$ corresponding to the partition $x_0 = 0, x_1 = \frac{2}{3}, x_2 = \frac{4}{3}, x_3 = 2$, with $x_1^* = \frac{1}{3}, x_2^* = 1$, and $x_3^* = \frac{5}{3}$. [4]

Solutions.

1. The Right-hand Rule comes down to the formula:

$$\int_a^b f(x) dx = \lim_{n \rightarrow \infty} \sum_{i=1}^n f\left(a + i \frac{b-a}{n}\right) \cdot \frac{b-a}{n}$$

In this problem, $f(x) = 2x^2 + 1$, $a = 0$, and $b = 3$:

$$\begin{aligned} \int_0^3 (2x^2 + 1) dx &= \lim_{n \rightarrow \infty} \sum_{i=1}^n \left(2 \left(0 + i \frac{3-0}{n} \right)^2 + 1 \right) \cdot \frac{3-0}{n} \\ &= \lim_{n \rightarrow \infty} \frac{3}{n} \sum_{i=1}^n \left(2 \frac{9i^2}{n^2} + 1 \right) \\ &= \lim_{n \rightarrow \infty} \frac{3}{n} \left[\sum_{i=1}^n \left(\frac{18i^2}{n^2} \right) + \sum_{i=1}^n 1 \right] \\ &= \lim_{n \rightarrow \infty} \frac{3}{n} \left[\frac{18}{n^2} \sum_{i=1}^n i^2 + n \right] \\ &= \lim_{n \rightarrow \infty} \frac{3}{n} \left[\frac{18}{n^2} \cdot \frac{n(n+1)(2n+1)}{6} + n \right] \\ &= \lim_{n \rightarrow \infty} \frac{3}{n} \left[\frac{3}{n} (n+1)(2n+1) + n \right] \\ &= \lim_{n \rightarrow \infty} \frac{3}{n} \left[\frac{3}{n} (2n^2 + 3n + 1) + n \right] \\ &= \lim_{n \rightarrow \infty} \frac{3}{n} \left[6n + 9 + \frac{3}{n} + n \right] \\ &= \lim_{n \rightarrow \infty} \frac{3}{n} \left[7n + 9 + \frac{3}{n} \right] \\ &= \lim_{n \rightarrow \infty} \left[21 + \frac{27}{n} + \frac{9}{n^2} \right] \\ &= 21 + 0 + 0 = 21 \end{aligned}$$

One could skip the odd step here or there ... ■

2. The Riemann sum for $\int_0^2 (3x+1)dx$ for the given partition and choice of points is (and evaluates to):

$$\begin{aligned} \sum_{i=1}^3 f(x_i^*) \cdot (x_i - x_{i-1}) &= \sum_{i=1}^3 (3x_i^* + 1) \cdot (x_i - x_{i-1}) \\ &= \left(3 \cdot \frac{1}{3} + 1\right) \left(\frac{2}{3} - 0\right) + (3 \cdot 1 + 1) \left(\frac{4}{3} - \frac{2}{3}\right) + \left(3 \cdot \frac{5}{3} + 1\right) \left(2 - \frac{4}{3}\right) \\ &= 2 \cdot \frac{2}{3} + 4 \cdot \frac{2}{3} + 6 \cdot \frac{2}{3} = \frac{4}{3} + \frac{8}{3} + \frac{12}{3} = \frac{4+8+12}{3} = \frac{24}{3} = 8 \quad \blacksquare \end{aligned}$$

Quiz #10. Friday, 7 December, 2001. [20 minutes]

Given that $\int_1^4 x dx = 7.5$ and $\int_1^4 x^2 dx = 21$, use the properties of definite integrals to:

1. Evaluate $\int_1^4 (x+1)^2 dx$. [5]
2. Find upper and lower bounds for $\int_1^4 x^{3/2} dx$. [5]

Solutions.

1. Using the given data and some properties of definite integrals:

$$\begin{aligned} \int_1^4 (x+1)^2 dx &= \int_1^4 (x^2 + 2x + 1) dx \\ &= \int_1^4 x^2 dx + \int_1^4 2x dx + \int_1^4 1 dx \\ &= 21 + 2 \int_1^4 x dx + 1 \cdot (4 - 1) \\ &= 21 + 2 \cdot 7.5 + 3 \\ &= 21 + 15 + 3 = 39 \quad \blacksquare \end{aligned}$$

2. First, note that $x \leq x^{3/2} \leq x^2$ when $x \geq 1$. Using the given data and the order properties of definite integrals gives:

$$7.5 = \int_1^4 x dx \leq \int_1^4 x^{3/2} dx \leq \int_1^4 x^2 dx = 21$$

Thus 7.5 is a lower bound and 21 is an upper bound for $\int_1^4 x^{3/2} dx$. ■

Quiz #11. Friday, 11 January, 2002. [15 minutes]

1. Compute the indefinite integral $\int (x^2 + x + 1)^3 (4x + 2) dx$. [5]
2. Find the area under the graph of $f(x) = \sin(x) \cos(x)$ for $0 \leq x \leq \frac{\pi}{2}$. [5]

Solutions.

1. We will use the substitution $u = x^2 + x + 1$ to compute the integral; note that $du = (2x + 1)dx$.

$$\begin{aligned} \int (x^2 + x + 1)^3 (4x + 2) dx &= \int (x^2 + x + 1)^3 2(2x + 1) dx \\ &= \int u^3 2du = 2 \frac{u^4}{4} + c = \frac{1}{2} u^4 + c = \frac{1}{2} (x^2 + x + 1)^4 + c \quad \blacksquare \end{aligned}$$

2. First, note that both $\sin(x)$ and $\cos(x)$, and hence also $\sin(x) \cos(x)$, are non-negative for $0 \leq x \leq \frac{\pi}{2}$. Hence the area under the graph of $f(x) = \sin(x) \cos(x)$ for $0 \leq x \leq \frac{\pi}{2}$ is given by the definite integral $\int_0^{\pi/2} \sin(x) \cos(x) dx$. We will compute this integral using the substitution $u = \sin(x)$, so $du = \cos(x)dx$. Note also that $u = 0$ when $x = 0$ and $u = 1$ when $x = \frac{\pi}{2}$.

$$\int_0^{\pi/2} \sin(x) \cos(x) dx = \int_0^1 u du = \frac{u^2}{2} \Big|_0^1 = \frac{1^2}{2} - \frac{0^2}{2} = \frac{1}{2} \quad \blacksquare$$

Quiz #12. Friday, 18 January, 2002. [15 minutes]

1. Compute $\int_1^e \frac{\ln(x^2)}{x} dx$. [5]
2. Find the area of the region between the curves $y = x^3 - x$ and $y = x - x^3$. [5]

Solutions.

1. We'll compute the integral using the substitution $u = \ln(x)$, so $du = \frac{1}{x}dx$. Note that $\ln(x^2) = 2\ln(x)$, and that $u = 0$ when $x = 1$ and $u = 1$ when $x = e$.

$$\int_1^e \frac{\ln(x^2)}{x} dx = \int_1^e \frac{2\ln(x)}{x} dx = \int_0^1 2u du = 2 \frac{u^2}{2} \Big|_0^1 = u^2 \Big|_0^1 = 1^2 - 0^2 = 1 \quad \blacksquare$$

2. First, we need to find the points where these curves intersect:

$$x^3 - x = x - x^3 \Leftrightarrow 2x^3 = 2x \Leftrightarrow x^3 = x$$

$x = 0$ is one solution to $x^3 = x$; when $x \neq 0$, we can divide the equation by x to get $x^2 = 1$, so $x = -1$ and $x = 1$ are the other solutions to $x^3 = x$. From -1 to 0 , $x^3 - x \geq x - x^3$, and from 0 to 1 , $x - x^3 \geq x^3 - x$. (This can be done with some algebra and knowledge of

inequalities, or you can just test each expression at some points in between, *e.g.* $x = -\frac{1}{2}$ and $x = \frac{1}{2}$.)

The area between the two curves is then given by:

$$\begin{aligned}
 & \int_{-1}^0 [(x^3 - x) - (x - x^3)] dx + \int_0^1 [(x - x^3) - (x^3 - x)] dx \\
 &= \int_{-1}^0 [2x^3 - 2x] dx + \int_0^1 [2x - 2x^3] dx \\
 &= \left[2\frac{x^4}{4} - 2\frac{x^2}{2} \right]_{-1}^0 + \left[2\frac{x^2}{2} - 2\frac{x^4}{4} \right]_0^1 \\
 &= \left[\frac{x^4}{2} - x^2 \right]_{-1}^0 + \left[x^2 - \frac{x^4}{2} \right]_0^1 \\
 &= \left[\left(\frac{0^4}{2} - 0^2 \right) - \left(\frac{(-1)^4}{2} - (-1)^2 \right) \right] + \left[\left(1^2 - \frac{1^4}{2} \right) - \left(0^2 - \frac{0^4}{2} \right) \right] \\
 &= \left[0 - \left(-\frac{1}{2} \right) \right] + \left[\frac{1}{2} - 0 \right] \\
 &= \frac{1}{2} + \frac{1}{2} = 1 \quad \blacksquare
 \end{aligned}$$

Quiz #13. Friday, 25 January, 2002. [19 minutes]

1. Find the volume of the solid obtained by revolving the region in the first quadrant bounded by $y = \frac{1}{x}$, $y = x$, and $x = 2$ about the x -axis. [10]

Solution.

1. First, we find where the curves intersect. $y = \frac{1}{x}$ and $y = x$ intersect when $\frac{1}{x} = x$, *i.e.* when $x^2 = 1$. Since we are looking for a region in the first quadrant, we discard the root $x = -1$ and keep $x = 1$; plugging into either equation for y gives us the point $(1, 1)$. $y = \frac{1}{x}$ and $x = 2$ intersect at the point $(2, \frac{1}{2})$, and $y = x$ and $x = 2$ intersect at $(2, 2)$. It is not too hard — if one is careful! — to deduce that the region is bounded above by $y = x$ and below by $y = \frac{1}{x}$ for $1 \leq x \leq 2$. Rotating this region about the x -axis gives the solid sketched below.

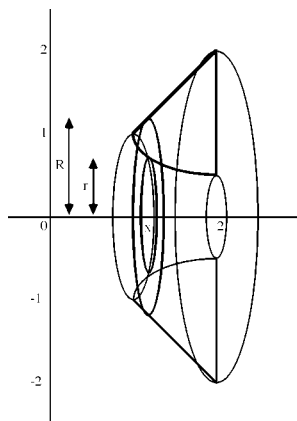

We will find the volume of this solid using the washer method. (A typical washer for this solid is also drawn in the sketch.) Since we rotated about a horizontal line, the washers will be stacked along this line (the x -axis) and so we will need to integrate with respect to x . Note that the outer radius of the washer at x is $R = x$ and the inner radius is $r = \frac{1}{x}$, so the volume is given by:

$$\begin{aligned} \int_1^2 (\pi R^2 - \pi r^2) dx &= \pi \int_1^2 \left(x^2 - \frac{1}{x^2} \right) dx \\ &= \pi \left(\frac{x^3}{3} - \frac{-1}{x} \right) \Big|_1^2 \\ &= \pi \left(\frac{x^3}{3} + \frac{1}{x} \right) \Big|_1^2 \\ &= \pi \left[\left(\frac{8}{3} + \frac{1}{2} \right) - \left(\frac{1}{3} + 1 \right) \right] \\ &= \frac{11}{6} \pi \quad \blacksquare \end{aligned}$$

Quiz #14. Friday, 1 February, 2002. [17 minutes]

1. Suppose the region bounded above by $y = 1$ and below by $y = x^2$ is revolved about the line $x = 2$. Sketch the resulting solid and find its volume. [10]

Solution.

1. $y = 1$ intersects $y = x^2$ when $x^2 = 1$, *i.e.* when $x = \pm 1$. The region between $y = 1$ and $y = x^2$, $-1 \leq x \leq 1$, when revolved about $x = 2$, gives the solid sketched below.

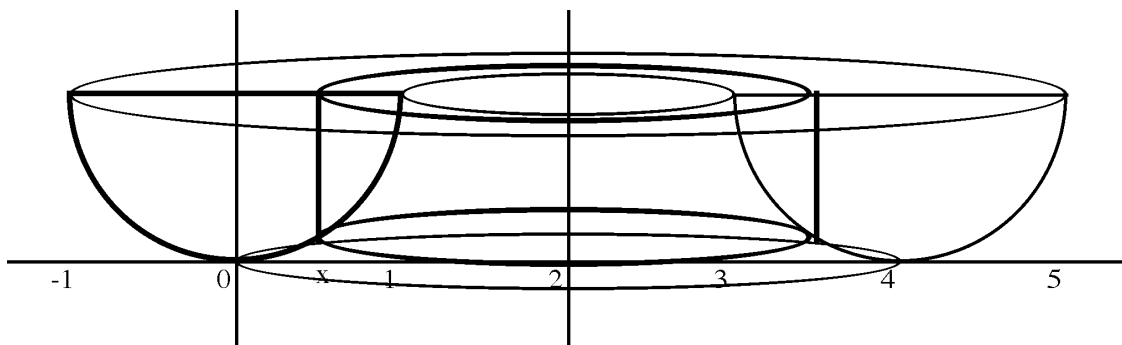

We will find the volume of this solid using the shell method. (A typical cylindrical shell for this solid is also drawn in the sketch.) Since we rotated about a vertical line, the shell will be nested around this line ($x = 2$) and so we will need to integrate with respect to x in order to integrate in a direction perpendicular to the shells. Note that the radius

of the shell at x is $r = 2 - x$ and the height is $h = 1 - x^2$, so the volume is given by:

$$\begin{aligned}
 \int_{-1}^1 2\pi r h \, dx &= \int_{-1}^1 2\pi(2-x)(1-x^2) \, dx \\
 &= \pi \int_{-1}^1 (4 - 2x - 4x^2 + 2x^3) \, dx \\
 &= \pi \left(4x - x^2 - \frac{4}{3}x^3 + \frac{1}{2}x^4 \right) \Big|_{-1}^1 \\
 &= \pi \left[\left(4 - 1 - \frac{4}{3} + \frac{1}{2} \right) - \left(-4 - 1 + \frac{4}{3} + \frac{1}{2} \right) \right] \\
 &= \frac{16}{3}\pi \quad \blacksquare
 \end{aligned}$$

Quiz #15. Friday, 15 February, 2002. [25 minutes]

Evaluate each of the following integrals.

$$1. \int_0^{\pi/4} \tan^2(x) \, dx \quad [4] \qquad 2. \int \sqrt{x^2 + 4x + 5} \, dx \quad [6]$$

Solution.

1.

$$\begin{aligned}
 \int_0^{\pi/4} \tan^2(x) \, dx &= \int_0^{\pi/4} (\sec^2(x) - 1) \, dx \\
 &= (\tan(x) - x) \Big|_0^{\pi/4} = \left(1 - \frac{\pi}{4} \right) - (0 - 0) = 1 - \frac{\pi}{4} \quad \blacksquare
 \end{aligned}$$

2.

$$\begin{aligned}
 \int \sqrt{x^2 + 4x + 5} \, dx &= \int \sqrt{(x+2)^2 + 1} \, dx \\
 &\text{Let } w = x + 2, \text{ so } dw = dx. \\
 &= \int \sqrt{w^2 + 1} \, dw \\
 &\text{Let } w = \tan(t), \text{ so } dw = \sec^2(t) dt. \\
 &= \int \sqrt{\tan^2(t) + 1} \sec^2(t) \, dt = \int \sqrt{\sec^2(t)} \sec^2(t) \, dt \\
 &= \int \sec^3(t) \, dt
 \end{aligned}$$

We will use integration by parts to compute this trig integral. Let $u = \sec(t)$ and $dv = \sec^2(t)dt$, so $du = \sec(t)\tan(t)dt$ and $v = \tan(t)$. Then

$$\begin{aligned}\int \sec^3(t) dt &= \sec(t)\tan(t) - \int \sec(t)\tan^2(t) dt \\ &= \sec(t)\tan(t) - \int \sec(t)(\sec^2(t) - 1) dt \\ &= \sec(t)\tan(t) - \int (\sec^3(t) - \sec(t)) dt \\ &= \sec(t)\tan(t) - \int \sec^3(t) dt + \int \sec(t) dt\end{aligned}$$

It follows that

$$2 \int \sec^3(t) dt = \sec(t)\tan(t) + \int \sec(t) dt,$$

so

$$\begin{aligned}\int \sec^3(t) dt &= \frac{1}{2} \left[\sec(t)\tan(t) + \int \sec(t) dt \right] \\ &= \frac{1}{2} \sec(t)\tan(t) + \frac{1}{2} \ln(\sec(t) + \tan(t)) + C.\end{aligned}$$

(It really helps to have memorized that $\int \sec(t) dt = \ln(\sec(t) + \tan(t)) + C \dots$)
It remains for us to substitute back to put the answer in terms of x :

$$\begin{aligned}\int \sqrt{x^2 + 4x + 5} dx &= \int \sec^3(t) dt \\ &= \frac{1}{2} \sec(t)\tan(t) + \frac{1}{2} \ln(\sec(t) + \tan(t)) + C \\ &= \frac{1}{2} w\sqrt{1+w^2} + \frac{1}{2} \ln(w + \sqrt{1+w^2}) + C \\ &\quad \dots \text{ since when } \tan(t) = w, \sec(t) = \sqrt{1+w^2}. \\ &= \frac{1}{2}(x+2)\sqrt{1+(x+2)^2} + \frac{1}{2} \ln\left((x+2) + \sqrt{1+(x+2)^2}\right) + C \quad \blacksquare\end{aligned}$$

Quiz #16. Friday, 1 March, 2002. [25 minutes]

1. Evaluate the following integral:

$$\int \frac{x^2 - 2x - 6}{(x^2 + 2x + 5)(x - 1)} dx$$

Solution. This is a job for partial fractions. First, note that the quadratic factor in the denominator is irreducible since $x^2 + 2x + 5 = x^2 + 2x + 1 + 4 = (x + 1)^2 + 4 > 0$ for all x . Thus

$$\frac{x^2 - 2x - 6}{(x^2 + 2x + 5)(x - 1)} = \frac{Ax + B}{x^2 + 2x + 5} + \frac{C}{x - 1}$$

for some constants A , B , and C . Putting the right-hand side of the equation above over a common denominator of $x(x-1)^2$ would give a numerator equal to the numerator of the left-hand side:

$$\begin{aligned}x^2 - 2x - 6 &= (Ax + B)(x - 1) + C(x^2 + 2x + 5) \\ &= Ax^2 - Ax + Bx - B + Cx^2 + 2Cx + 5C \\ &= (A + C)x^2 + (-A + B + 2C)x + (-B + 5C)\end{aligned}$$

Thus $A + C = 1$, $-A + B + 2C = -2$, and $-B + 5C = -6$, which equations we need to solve for A , B , and C . From the first and third of these equations we get that $A = 1 - C$ and $B = 6 + 5C$. Plugging these into the second equation gives $-2 = -(1 - C) + (6 + 5C) + 2C = 5 - 8C$, so $C = -7/8$. It follows that $A = 15/8$ and $B = 13/8$. Hence:

$$\begin{aligned}\int \frac{x^2 - 2x - 6}{(x^2 + 2x + 5)(x - 1)} dx &= \int \left[\frac{\frac{15}{8}x + \frac{13}{8}}{x^2 + 2x + 5} + \frac{-\frac{7}{8}}{x - 1} \right] dx \\ &= \frac{1}{8} \int \frac{15x + 13}{x^2 + 2x + 5} dx - \frac{7}{8} \int \frac{1}{x - 1} dx\end{aligned}$$

If $u = x^2 + 2x + 5$, then $du = (2x + 2)dx = 2(x + 1)dx$, so we want to split $15x + 13$ into a multiple of $x + 1$ plus a constant.

$$\begin{aligned}&= \frac{1}{8} \int \frac{15(x + 1) - 2}{x^2 + 2x + 5} dx - \frac{7}{8} \ln(x - 1) \\ &= \frac{1}{8} \int \frac{15(x + 1)}{x^2 + 2x + 5} dx - \frac{1}{8} \int \frac{-2}{x^2 + 2x + 5} dx - \frac{7}{8} \ln(x - 1)\end{aligned}$$

Use the substitution $u = x^2 + 2x + 5$ in the first part, and complete the square in the second part.

$$= \frac{15}{8} \int \frac{1}{u} \frac{1}{2} du + \frac{2}{8} \int \frac{1}{(x + 1)^2 + 4} dx - \frac{7}{8} \ln(x - 1)$$

Use the substitution $w = x + 1$, so $dw = dx$, in the second part.

$$= \frac{15}{16} \ln(u) + \frac{1}{4} \int \frac{1}{w^2 + 4} dw - \frac{7}{8} \ln(x - 1)$$

Substitute back in the first part, and substitute $w = 2s$, so $dw = 2ds$ in the second.

$$\begin{aligned}&= \frac{15}{16} \ln(x^2 + 2x + 5) + \frac{1}{4} \int \frac{1}{4s^2 + 4} 2ds - \frac{7}{8} \ln(x - 1) \\ &= \frac{15}{16} \ln(x^2 + 2x + 5) + \frac{1}{4} \cdot \frac{2}{4} \int \frac{1}{s^2 + 1} ds - \frac{7}{8} \ln(x - 1) \\ &= \frac{15}{16} \ln(x^2 + 2x + 5) + \frac{1}{8} \arctan(s) - \frac{7}{8} \ln(x - 1) + K\end{aligned}$$

... where K is a constant.

$$\begin{aligned} &= \frac{15}{16} \ln(x^2 + 2x + 5) + \frac{1}{8} \arctan\left(\frac{w}{2}\right) - \frac{7}{8} \ln(x - 1) + K \\ &= \frac{15}{16} \ln(x^2 + 2x + 5) + \frac{1}{8} \arctan\left(\frac{x - 1}{2}\right) - \frac{7}{8} \ln(x - 1) + K \end{aligned}$$

Whew! ■

Quiz #17. Friday, 8 March, 2002. [25 minutes]

1. Evaluate the following integral:

$$\int_2^{\infty} \frac{1}{x(x-1)^2} dx$$

Solution. Note that $x(x-1)^2 \neq 0$ for all x with $2 \leq x < \infty$, so we don't have to worry about the integral being improper except by way of the upper limit of ∞ . By definition,

$$\int_2^{\infty} \frac{1}{x(x-1)^2} dx = \lim_{t \rightarrow \infty} \int_2^t \frac{1}{x(x-1)^2} dx$$

which leaves us with the task of integrating $\int_2^t \frac{1}{x(x-1)^2} dx$ and then evaluating the limit as $t \rightarrow \infty$.

Computing the integral requires us to decompose $\frac{1}{x(x-1)^2}$ using partial fractions. Note that the numerator has degree less than the degree of the denominator, but that we do have a repeated factor in the denominator. Thus

$$\frac{1}{x(x-1)^2} = \frac{A}{x} + \frac{B}{x-1} + \frac{C}{(x-1)^2}$$

for some constants A , B , and C . Putting the right-hand side of the equation above over a common denominator of $x(x-1)^2$ would give a numerator equal to the numerator of the left-hand side:

$$\begin{aligned} 1 &= A(x-1)^2 + Bx(x-1) + Cx \\ &= A(x^2 - 2x + 1) + B(x^2 - x) + Cx \\ &= (A+B)x^2 + (-2A-B+C)x + A. \end{aligned}$$

Thus $A+B=0$, $-2A-B+C=0$, and $A=1$, from which it quickly follows that $A=1$,

$B = -1$, and $C = 1$. Hence

$$\begin{aligned}
 \int_2^\infty \frac{1}{x(x-1)^2} dx &= \lim_{t \rightarrow \infty} \int_2^t \frac{1}{x(x-1)^2} dx \\
 &= \lim_{t \rightarrow \infty} \int_2^t \left[\frac{1}{x} + \frac{-1}{x-1} + \frac{1}{(x-1)^2} \right] dx \\
 &= \lim_{t \rightarrow \infty} \left[\int_2^t \frac{1}{x} dx - \int_2^t \frac{1}{x-1} dx + \int_2^t \frac{1}{(x-1)^2} dx \right] \\
 &= \lim_{t \rightarrow \infty} \left[\ln(x) \Big|_2^t - \ln(x-1) \Big|_2^t + \frac{-1}{(x-1)} \Big|_2^t \right] \\
 &= \lim_{t \rightarrow \infty} \left[(\ln(t) - \ln(2)) - (\ln(t-1) - \ln(2-1)) + \left(\frac{-1}{(t-1)} - \frac{-1}{(2-1)} \right) \right] \\
 &= \lim_{t \rightarrow \infty} \left[\ln(t) - \ln(t-1) - \frac{1}{(t-1)} - \ln(2) + \ln(1) + \frac{1}{1} \right] \\
 &= \lim_{t \rightarrow \infty} \left[\ln \left(\frac{t}{t-1} \right) - \frac{1}{(t-1)} - \ln(2) + 0 + 1 \right] \\
 &= 1 - \ln(2)
 \end{aligned}$$

since $\lim_{t \rightarrow \infty} \frac{t}{t-1} = \lim_{t \rightarrow \infty} \frac{1}{1-1/t} = \frac{1}{1-0} = 1$, so $\lim_{t \rightarrow \infty} \ln \left(\frac{t}{t-1} \right) = \ln(1) = 0$, while $\lim_{t \rightarrow \infty} \frac{1}{(t-1)} = 0$.

■

Quiz #18. Friday, 15 March, 2002. [18 minutes]

Determine whether each of the following series converges or diverges.

$$1. \quad \sum_{n=0}^{\infty} \left[\frac{1}{n+1} + \frac{3^n}{3^n+1} \right] \quad [4] \quad 2. \quad \sum_{n=0}^{\infty} \frac{253}{3^n+1} \quad [6]$$

Solutions.

1. We will apply the Divergence Test.

$$\begin{aligned}
 \lim_{n \rightarrow \infty} \left[\frac{1}{n+1} + \frac{3^n}{3^n+1} \right] &= \left[\lim_{n \rightarrow \infty} \frac{1}{n+1} \right] + \left[\lim_{n \rightarrow \infty} \frac{3^n}{3^n+1} \right] = 0 + \lim_{n \rightarrow \infty} \frac{3^n}{3^n+1} \cdot \frac{1/3^n}{1/3^n} \\
 &= \lim_{n \rightarrow \infty} \frac{1}{1+1/3^n} = \frac{1}{1+0} = 1 \neq 0
 \end{aligned}$$

It follows that the given series diverges. ■

2. We will apply the Comparison Test. Note that

$$0 < \frac{253}{3^n+1} < \frac{253}{3^n}$$

for all $n \geq 0$, because reducing the denominator increases the fraction. The series $\sum_{n=0}^{\infty} \frac{253}{3^n}$ is a geometric series with $a = 253$ and $r = \frac{1}{3}$, and since $|\frac{1}{3}| < 1$, it converges. It follows by the Comparison Test that the given series converges as well. ■

Bonus Quiz. Monday, 18 March, 2002. [15 minutes]

Compute any *two* of 1–3.

$$1. \lim_{t \rightarrow \infty} te^{-t} \quad [5] \quad 2. \int_0^{\infty} te^{-t} dt \quad [5] \quad 3. \sum_{n=0}^{\infty} \frac{1}{n^2 + 3n + 2} \quad [5]$$

Solutions.

1. $\lim_{t \rightarrow \infty} te^{-t} = \lim_{t \rightarrow \infty} \frac{t}{e^t} = \lim_{t \rightarrow \infty} \frac{\frac{d}{dt}t}{\frac{d}{dt}e^t} = \lim_{t \rightarrow \infty} \frac{1}{e^t} = 0$, using l'Hôpital's Rule and the fact that $\lim_{t \rightarrow \infty} e^t = \infty$. ■

2. We'll need l'Hôpital's Rule and the fact that $\lim_{s \rightarrow \infty} e^s = \infty$ again:

$$\int_0^{\infty} te^{-t} dt = \lim_{s \rightarrow \infty} \int_0^s te^{-t} dt$$

Use integration by parts with $u = t$ and $dv = e^{-t}dt$, so $du = dt$ and $v = -e^{-t}$.

$$\begin{aligned} &= \lim_{s \rightarrow \infty} \left[-te^{-t} \Big|_0^s - \int_0^s (-e^{-t}) dt \right] \\ &= \lim_{s \rightarrow \infty} \left[(-se^{-s}) - (-0e^{-0}) - e^{-t} \Big|_0^s \right] \\ &= \lim_{s \rightarrow \infty} \left[-se^{-s} - (e^{-s} - e^{-0}) \right] \\ &= \lim_{s \rightarrow \infty} \left[-se^{-s} - e^{-s} + 1 \right] \\ &= \lim_{s \rightarrow \infty} \left[-\frac{s}{e^s} - \frac{1}{e^s} \right] + 1 \\ &= \lim_{s \rightarrow \infty} \left[-\frac{\frac{d}{ds}s}{\frac{d}{ds}e^s} - 0 + 1 \right] \\ &= \lim_{s \rightarrow \infty} \left[-\frac{1}{e^s} \right] + 1 \\ &= -0 + 1 \\ &= 1 \quad \blacksquare \end{aligned}$$

3. Note that $n^2 + 3n + 2 = (n + 1)(n + 2)$ and that, using the usual partion fraction nonsense, $\frac{1}{n^2 + 3n + 2} = \frac{1}{n + 1} - \frac{1}{n + 2}$. Thus the k th partial sum of the given series

is

$$\begin{aligned} S_k &= \sum_{n=0}^k \frac{1}{n^2 + 3n + 2} = \sum_{n=0}^k \left(\frac{1}{n+1} - \frac{1}{n+2} \right) \\ &= \left(\frac{1}{0+1} - \frac{1}{0+2} \right) + \left(\frac{1}{1+1} - \frac{1}{1+2} \right) + \cdots + \left(\frac{1}{k+1} - \frac{1}{k+2} \right) \\ &= \left(\frac{1}{1} - \frac{1}{2} \right) + \left(\frac{1}{2} - \frac{1}{3} \right) + \left(\frac{1}{3} - \frac{1}{4} \right) + \cdots + \left(\frac{1}{k+1} - \frac{1}{k+2} \right) \\ &= 1 - \frac{1}{k+2}, \end{aligned}$$

so

$$\sum_{n=0}^{\infty} \frac{1}{n^2 + 3n + 2} = \lim_{k \rightarrow \infty} S_k = \lim_{k \rightarrow \infty} \left(1 - \frac{1}{k+2} \right) = 1 - 0 = 1. \quad \blacksquare$$

Quiz #19. Friday, 22 March, 2002. [20 minutes]

Determine whether each of the following series converges or diverges.

$$1. \quad \sum_{n=1}^{\infty} \frac{1}{n^n} \quad [5] \quad 2. \quad \sum_{n=0}^{\infty} \frac{4n+12}{n^2+6n+13} \quad [5]$$

Solutions.

1. We will use the Comparison Test. Note that for all $n > 2$, $n^n > 2^n$, so

$$0 < \frac{1}{n^n} < \frac{1}{2^n}.$$

$\sum_{n=1}^{\infty} \frac{1}{2^n}$ is the geometric series with $a = \frac{1}{2}$ and $r = \frac{1}{2}$, and it converges because $|r| = \frac{1}{2} < 1$. It follows by the Comparison Test that $\sum_{n=1}^{\infty} \frac{1}{n^n}$ converges as well.

One could also conveniently use the Limit Comparison Test. \blacksquare

2. We will use the Limit Comparison Test, comparing the given series to $\sum_{n=0}^{\infty} \frac{1}{n}$. (Why compare the given series to this one? Note that the terms of the given series are rational functions of n in which the top power in the numerator is one less than the top power in the denominator. $\frac{1}{n}$ is the simplest rational function with this pattern.)

Now:

$$\begin{aligned}\lim_{n \rightarrow \infty} \frac{\frac{1}{n}}{\frac{4n+12}{n^2+6n+13}} &= \lim_{n \rightarrow \infty} \frac{1}{n} \cdot \frac{n^2 + 6n + 13}{4n + 12} \\ &= \lim_{n \rightarrow \infty} \frac{n^2 + 6n + 13}{4n^2 + 12n} \\ &= \lim_{n \rightarrow \infty} \frac{n^2 + 6n + 13}{4n^2 + 12n} \cdot \frac{1/n^2}{1/n^2} \\ &= \lim_{n \rightarrow \infty} \frac{1 + \frac{6}{n} + \frac{13}{n^2}}{4 + \frac{12}{n}} \\ &= \frac{1 + 0 + 0}{4 + 0} = \frac{1}{4}\end{aligned}$$

Since $0 < \frac{1}{4} < \infty$, it follows by the Limit Comparison Test that the series $\sum_{n=0}^{\infty} \frac{1}{n}$ and

$\sum_{n=0}^{\infty} \frac{4n+12}{n^2+6n+13}$ both converge or both diverge. Since $\sum_{n=0}^{\infty} \frac{1}{n}$ is known to diverge, it must be the case that $\sum_{n=0}^{\infty} \frac{4n+12}{n^2+6n+13}$ diverges as well.

This problem could also be done using the Comparison Test or (very conveniently) the Integral Test. ■

Quiz #20. Tuesday, 2 April, 2002. [10 minutes]

1. Determine whether the series $\sum_{n=0}^{\infty} \frac{(-1)^n + \cos(n\pi)}{n+1}$ converges absolutely, converges conditionally, or diverges. [10]

Solution. The key here is that $\cos(n\pi) = (-1)^n$ since \cos is equal to 1 at even multiples of π and -1 at odd multiples of π . Hence

$$\sum_{n=0}^{\infty} \frac{(-1)^n + \cos(n\pi)}{n+1} = \sum_{n=0}^{\infty} \frac{(-1)^n + (-1)^n}{n+1} = \sum_{n=0}^{\infty} \frac{2 \cdot (-1)^n}{n+1} = 2 \sum_{n=0}^{\infty} \frac{(-1)^n}{n+1},$$

so the given series will converge (or not) exactly as $\sum_{n=0}^{\infty} \frac{(-1)^n}{n+1}$ does. However, this is a series beaten to death in class and the text in very slight disguise:

$$\sum_{n=0}^{\infty} \frac{(-1)^n}{n+1} = \frac{1}{1} - \frac{1}{2} + \frac{1}{3} - \frac{1}{4} + \dots = \sum_{k=1}^{\infty} \frac{(-1)^{k-1}}{k} = (-1) \sum_{k=1}^{\infty} \frac{(-1)^k}{k}$$

(Note that the indices are related via $k = n + 1$.)

We know already that $\sum_{k=1}^{\infty} \frac{(-1)^k}{k}$ converges – we showed that in class using the Alternating Series Test. It does not converge absolutely because $\sum_{k=1}^{\infty} \frac{1}{k}$ does not converge – we showed that, in effect using the Integral Test, on Assignment #6. Thus the series $\sum_{k=1}^{\infty} \frac{(-1)^k}{k}$, and hence given series too, converges conditionally. ■

Quiz #21. Friday, 5 April, 2002. [10 minutes]

1. Find a power series which, when it converges, equals $f(x) = \frac{3x^2}{(1-x^3)^2}$. [10]

Solution. Note that the derivative of part of the denominator $f(x)$, $\frac{d}{dx}(1-x^3) = -3x^2$, is a constant multiple to the numerator, $3x^2$. This makes it easy to integrate $f(x)$ using the substitution $u = 1 - x^3$ (so $du = -3x^2 dx$ and $(-1)du = 3x^2 dx$):

$$\begin{aligned} \int f(x) dx &= \int \frac{3x^2}{(1-x^3)^2} dx = \int \frac{1}{u^2} (-1)du = - \int u^{-2} du \\ &= -(-u^{-1}) + C = \frac{1}{u} + C = \frac{1}{1-x^3} + C \end{aligned}$$

The point here is that it is easy to find a power series representation of the antiderivative of $f(x)$ because $\frac{1}{1-x^3}$ is the sum of the geometric series with $a = 1$ and $r = x^3$. Thus:

$$\int f(x) dx = \frac{1}{1-x^3} + C = \sum_{n=0}^{\infty} (x^3)^n = \sum_{n=0}^{\infty} x^{3n}$$

The power series of $f(x)$ is the derivative of the power series for $\int f(x) dx$ (at least for those x for which this series converges absolutely):

$$f(x) = \frac{3x^2}{(1-x^3)^2} = \frac{d}{dx} \left(\sum_{n=0}^{\infty} x^{3n} \right) = \sum_{n=0}^{\infty} \frac{d}{dx} x^{3n} = \sum_{n=0}^{\infty} 3nx^{3n-1}$$

Note that the first term, for $n = 0$, has a coefficient of $3 \cdot 0 = 0$, so it doesn't matter that the corresponding power of x is negative. ■